

Capteur vendu séparément
Load cell sold separately

- Pour pesage de cuves et silos en toute sécurité
- Disponible en acier zingué ou inoxydable
- Dispositif anti-soulèvement et butées latérales de très forte capacité
- Montage pendulaire permettant la dilatation du réservoir en préservant la précision
- Boulons de maintien en position haute
- *Designed to weigh tanks and silos safely*
- *Zinc plated or stainless steel construction*
- *High capacity lift-off prevention device and cross stoppers*
- *Pendulum bearings allowing vessel expansion with maximum accuracy*
- *Integrated jacking bolts*

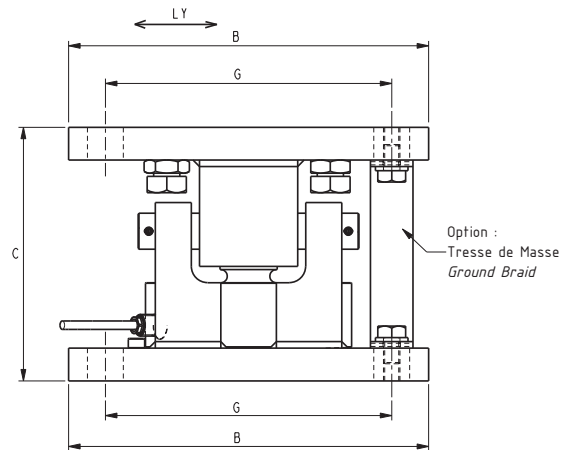
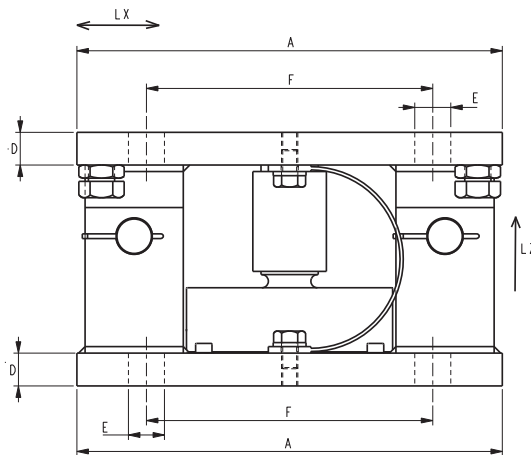

Modèle Model	A	B	C operation/installation	D	ØE	F	G	Poids Weight
15 t	180	180	135/140	20	18	140	140	14 kg
30 t	250	220	155/160	20	22	175	175	29 kg
100 t	370	300	240/250	30	26	220	220	90 kg

Toutes dimensions en mm. Dimensions et spécifications non contractuelles - All dimensions in mm. Dimensions and specifications do not constitute any liability whatsoever.
Dessins techniques disponibles sur demande - Technical drawings are available on request.

Caractéristiques - Specifications

TYPE	TYPE	SILOSAFE-R			
Matière	Material	Acier zingué - zinc plated steel			
Modèle	Model	15	30	100	t
Charge nominale R10X	R10X nominal load	1 ... 15	30	50 ... 100	t
Déplacement horizontal max.	Max. horizontal displacement	±5	±5	±10	mm
Angle horizontal max.	Max. horizontal angle	±1	±1	±3	°
Force de rappel (% force appliquée)	Restoring force (% applied force)	12	12	11	%
Force longitudinale max. (Lx)	Max. longitudinal force (Lx)	5	9	33	t
Force latérale max. (Ly)	Max. lateral force (Ly)	3.7	5	10	t
Anti-soulèvement max. (Lz)	Max. lift off force (Lz)	15	21	40	t

TYPE	TYPE	SILOSAFE-RX			
Matière	Material	Acier inoxydable - stainless steel			
Modèle	Model	15	30	-	t
Charge nominale R10X	R10X nominal load	1 ... 15	30	-	t
Déplacement horizontal max.	Max. horizontal displacement	±5	±5	-	mm
Angle horizontal max.	Max. horizontal angle	±1	±1	-	°
Force de rappel (% force appliquée)	Restoring force (% applied force)	12	12	-	%
Force longitudinale max. (Lx)	Max. longitudinal force (Lx)	2	3.7	-	t
Force latérale max. (Ly)	Max. lateral force (Ly)	1.6	2.5	-	t
Anti-soulèvement max. (Lz)	Max. lift off force (Lz)	6	9	-	t

Attention : toutes les charges indiquées sont des charges limites statiques - Be careful, all load are the static load limit.

Options - Options

Tresse de masse	Ground Braid	25 mm ²
-----------------	--------------	--------------------

Exemples de montage - Mounting examples

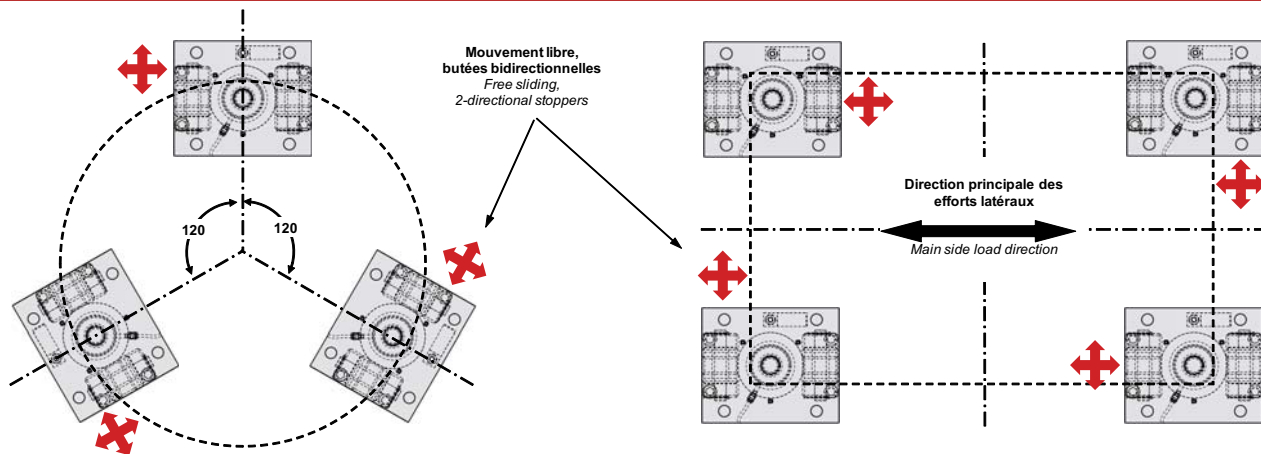

BP501 - F 74105 Annemasse Cedex
Tél. : (+33) 4 50 87 78 64
Fax : (+33) 4 50 87 78 42
E.mail : info@scaime.com



Téléchargez tous
nos documents sur :
Download all
our documents on :
www.scaime.com

Agent